

18

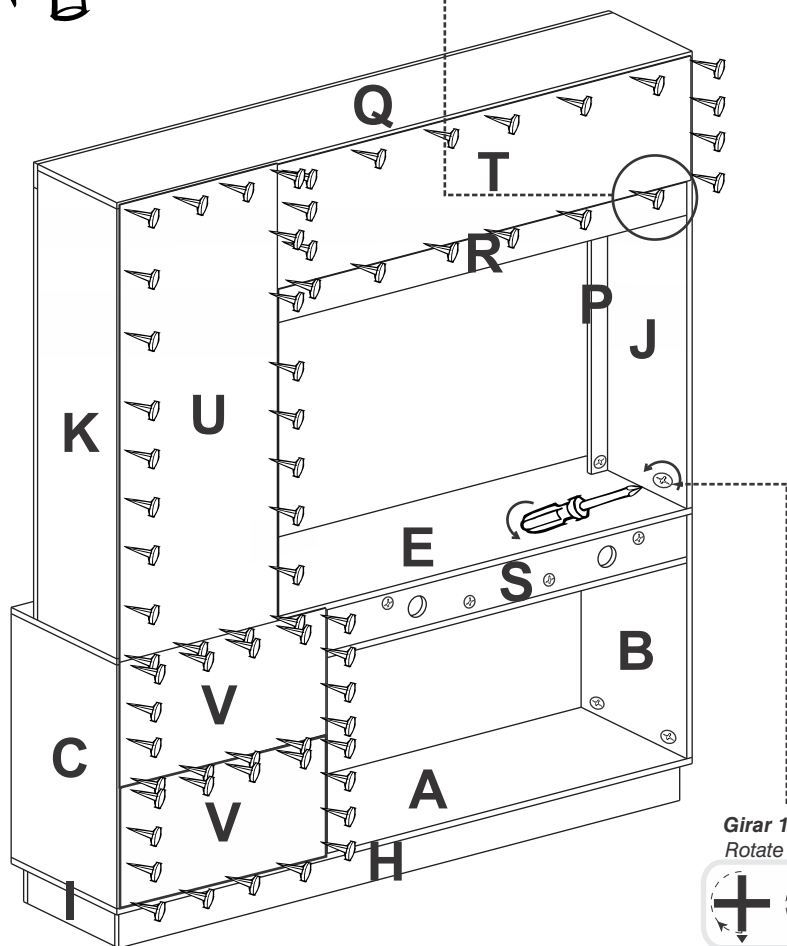

Girar 180° /
Rotate 180°

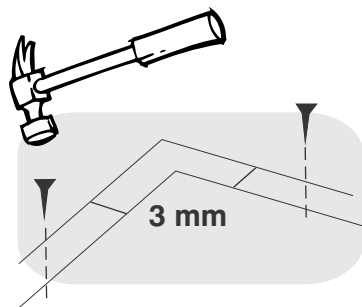
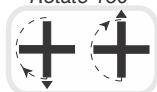

Al terminar de armar desprenda los adhesivos (en caso de que queden residuos de pegamento, limpie la superficie con alcohol) / When you finish off adhesive build (in case of residues of glue, wipe it with alcohol)



Al finalizar el ajuste de los conectores, proceda a poner las tapas adhesivas / When you finish the adjustment of the connectors, proceed to put the cover tapes

INSTRUCCIONES DE ARMADO CENTRO DE ENTRETENIMIENTO CANTABRIA

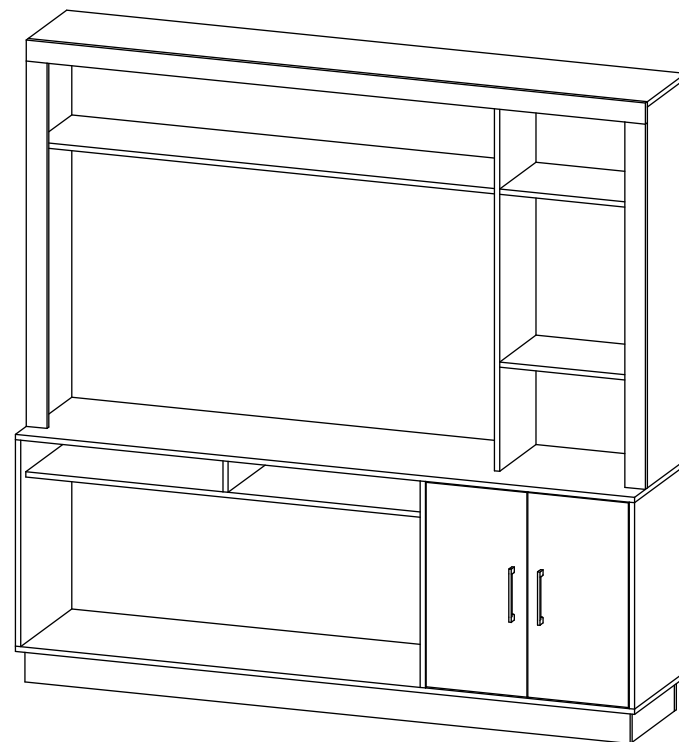

RTA[®]
m u e b l e s

Te

LOT N°

**RECOMENDACIONES IMPORTANTES
KEY RECOMMENDATIONS**

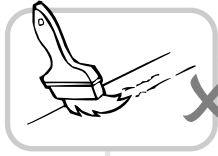

NO pinte el mueble/
Do not paint the
furniture.



NO mojar o ubicar
a la intemperie/
Do not expose to rain
or direct sun.

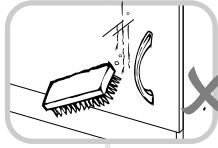
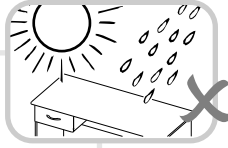

NO lavar las manijas o
tiraderas con jabones o
elementos abrasivos/
Don't wash handles
or dumps with soap or
abrasives.

NO sobrecargue el mueble.
no exceda el peso de 30 kilos
para gabinetes de cocina/
Do not overload the cabinet.
Weight not exceeding 66LB
for kitchen cabinets.

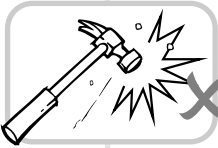

NO golpear ni martillar
el mueble (hágalo sólo
donde se indique) /
Don't hit or hammer
the furniture (just do it
where indicated).

NO permita que los niños
manipulen el mueble, puede
voltearse y lastimarnos/
Do not allow children to
handle the cabinets or
drawers.

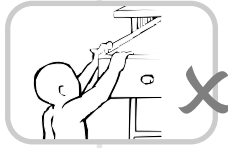

SIEMPRE levante el
mueble entre dos
personas, NO lo arrastre/
Do not drag the furniture.
Lift it between two people.

Limpie con paño seco y
lustrador de muebles,
de esta forma alarga la
vida del mueble/Clean with
a dry cloth. Polishing wax for
furniture can be use.



**HERRAJES BÁSICOS PARA MUEBLES RTA
BASIC HARDWARE FOR RTA FURNITURE**

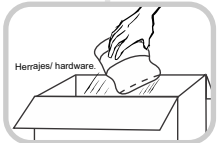

1. Abrir la caja del mueble
y buscar la bolsa con los
herrajes / Open the box
and look for the hardware
bag.

3. Separe los herrajes para
facilitar su identificación
durante el armado /
Separate hardware for easy
identification during
assembly.

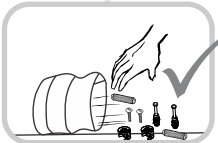
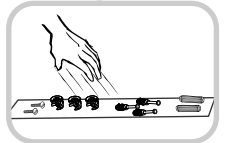

2. Abrir el paquete y
comprobar que el
contenido de las piezas es
correcto / Open the
package and verify that
the content of the pieces
is correct.

4. Arme el mueble en un
lugar limpio y en una
superficie plana / Assemble
the furniture in a clean
place and on a flat surface.

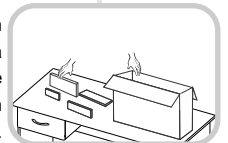

**MUEBLES MODULARES, CONSTRUYENDO HOGARES
/READY TO ASSEMBLE FURNITURE, BUILDING HOMES**

**INSTALACIÓN BISAGRAS/
HINGE INSTALLATION**

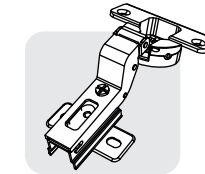
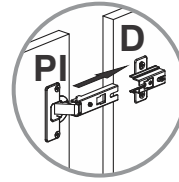

Bisagra interior/
Inset Hinge

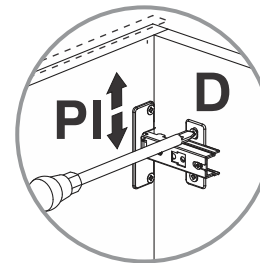
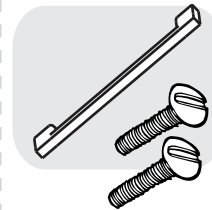
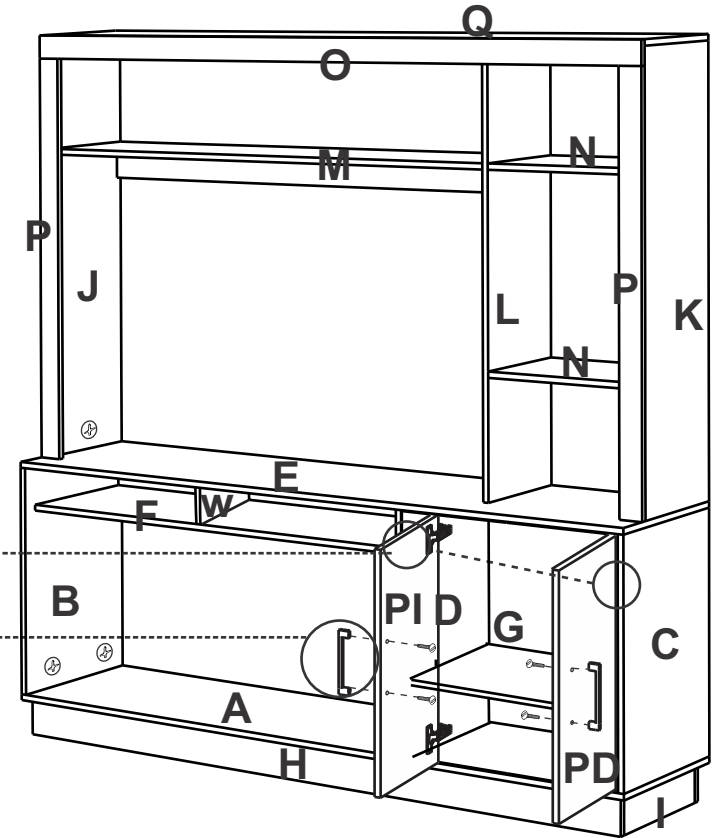

**AJUSTE DE
ALTURA / HEIGHT
ADJUSTMENT**

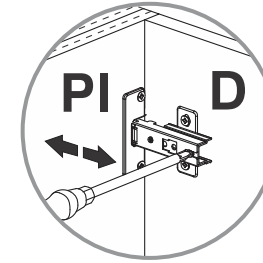

**AJUSTE DE
PROFUNDIDAD
/ DEPTH
ADJUSTMENT**

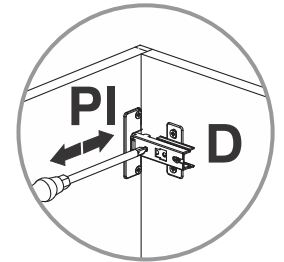

**AJUSTE LATERAL
/ LATERAL
ADJUSTMENT**

HERRAJES PARA ARMADO ASSEMBLY HARDWARE

x92

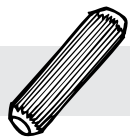

Tarugo/
Wooden pin

x47



Minifix/
Minifix Cams

x47

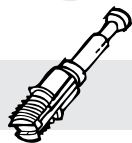

Perno minifix/
Spreading Bolt

x30



Tornillo Lámina/
Sheet metal screw

x70



Puntillas/
Nails

x47



Tapa Minifix/
Cover caps

x10



Deslizador
15mm/
Nail on Glide

x7

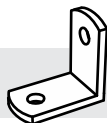

Cantonera n°2/
Wide Brace

x4

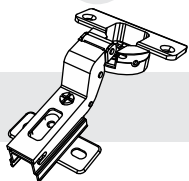

Bisagra Interior
35mm/ Inset Hinge

x2

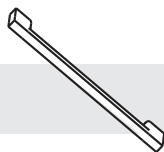

Manija zamak
160 cc/ Handle

x4



Tornillo manija/
Handle screw

x2



Soporte entrepaño/
Shelf Support



IMPORTANTE

TENER PRECAUCIÓN AL ABRIR LA BOLSA DE HERRAJES PARA NO EXTRAVIAR NINGUNO. COMPRUEBE QUE EL CONTENIDO DE LAS PIEZAS SEA EL CORRECTO. EN CASO QUE FALTE ALGUNA PIEZA O ESTE DEFECTUOSA DEVUELVA LAS PIEZAS AL ALMACÉN CON SU FACTURA PARA EFECTUAR EL CAMBIO DE LAS PIEZAS Y/O LOS HERRAJES LO MÁS PRONTO POSIBLE. / PLEASE BE CAUTIOUS WHEN OPENING THE HARDWARE BAG TO NOT LOSE ANY. CHECK THE CONTENTS OF THE PARTS ARE CORRECT. IF ANY PART IS MISSING OR DEFECTIVE PLEASE RETURN THE PARTS TO THE STORE WITH THE PRODUCT INVOICE ATTACHED TO MAKE EFFECTIVE THE REPLACEMENT OF THE DEFECTIVE PIECES OR WARDWARE AS SOON AS POSSIBLE.

13

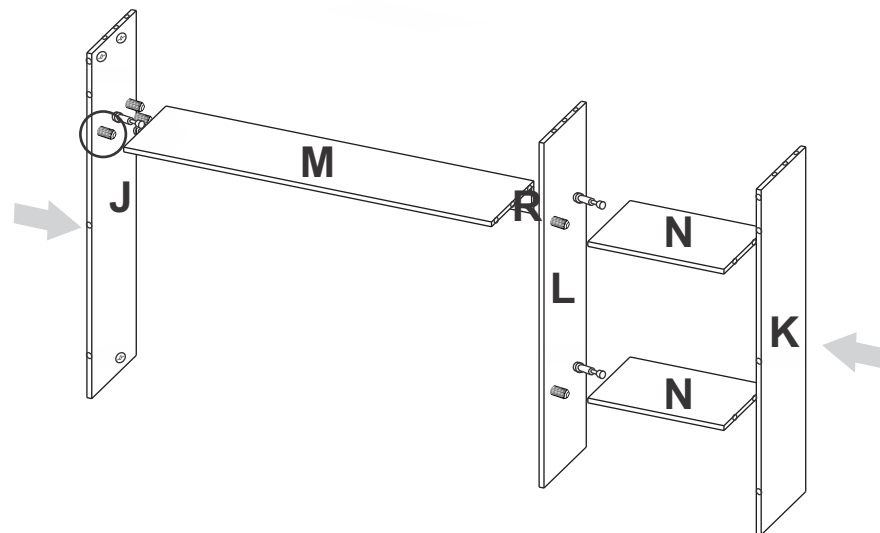

14

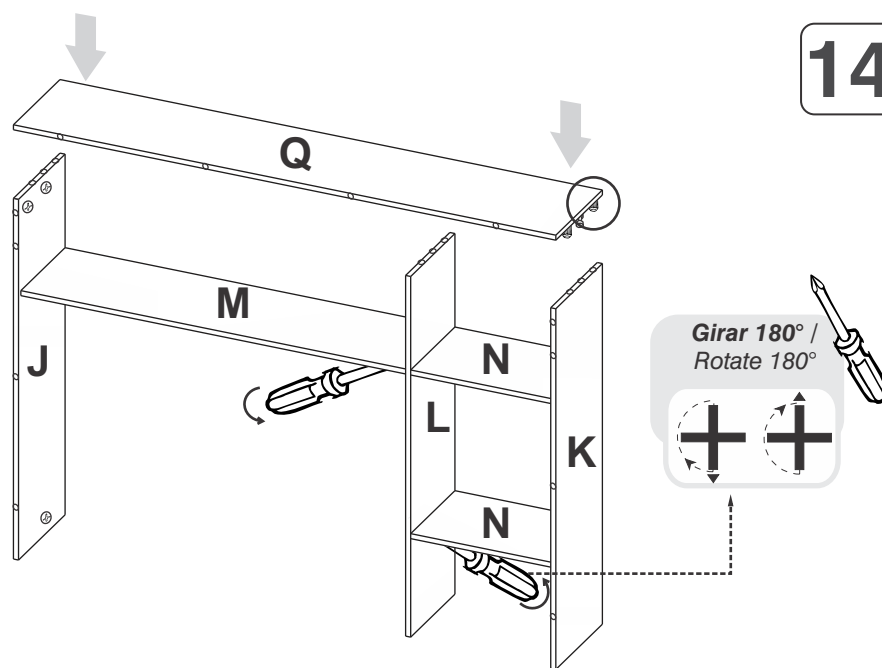

11

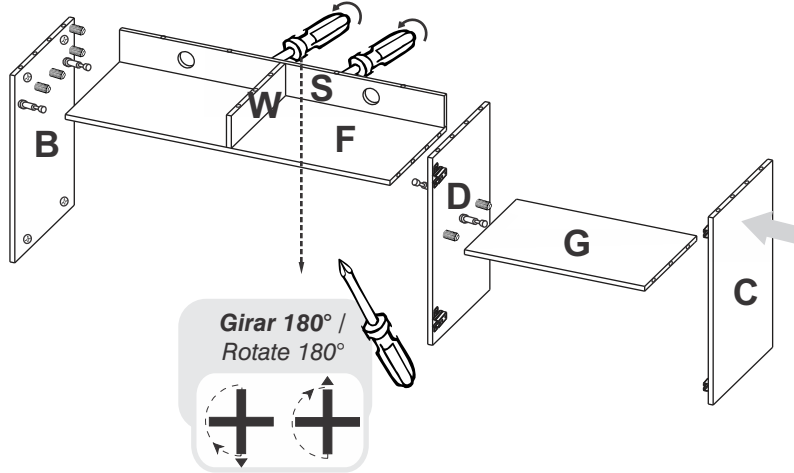

12

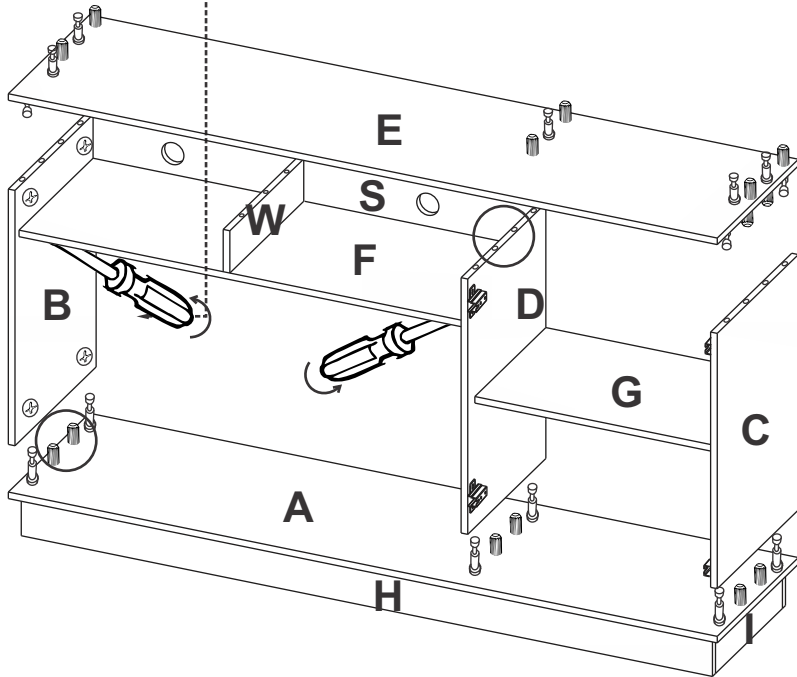

PIEZAS DE ARMADO
ASSEMBLY PARTS

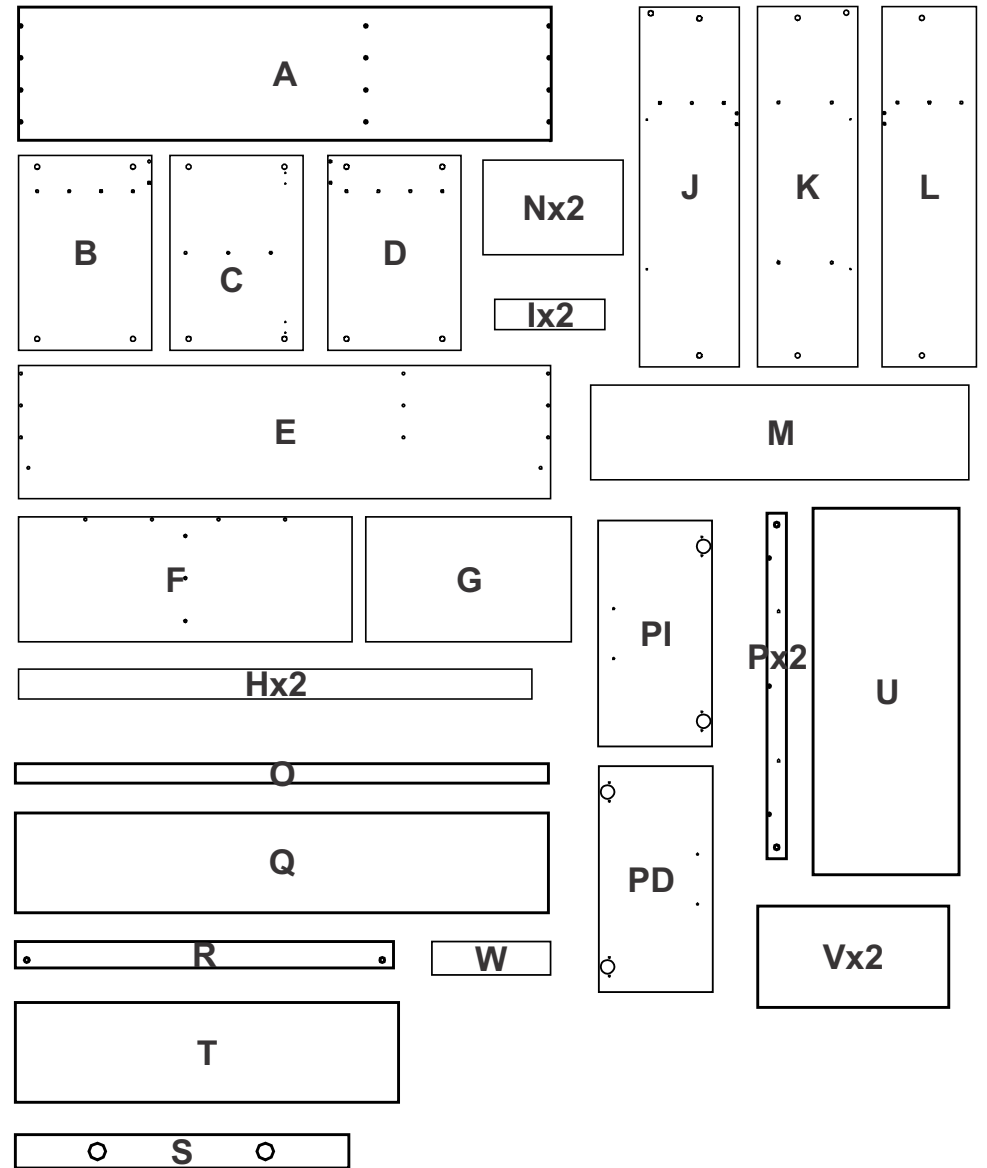

IMPORTANTE

ANTES DE EMPEZAR A ARMAR EL MUEBLE LEA DETENIDAMENTE LAS INSTRUCCIONES. SE RECOMIENDA ARMAR EL MUEBLE SOBRE LA CAJA O SOBRE UNA SUPERFICIE LISA Y CUBIERTA, PARA NO RAYARLO / BEFORE STARTING TO ASSEMBLE THE FURNITURE, CAREFULLY READ THE INSTRUCTIONS. IT IS RECOMMENDED TO ASSEMBLE THE FURNITURE ON THE BOX OR ON A FLAT AND COVERED SURFACE IN ORDER TO NOT SCRATCH THE PRODUCT.

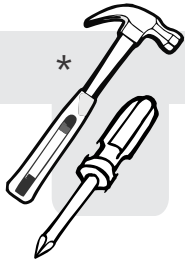

*

*(Herramientas NO incluidas) *Tools NOT Included

9

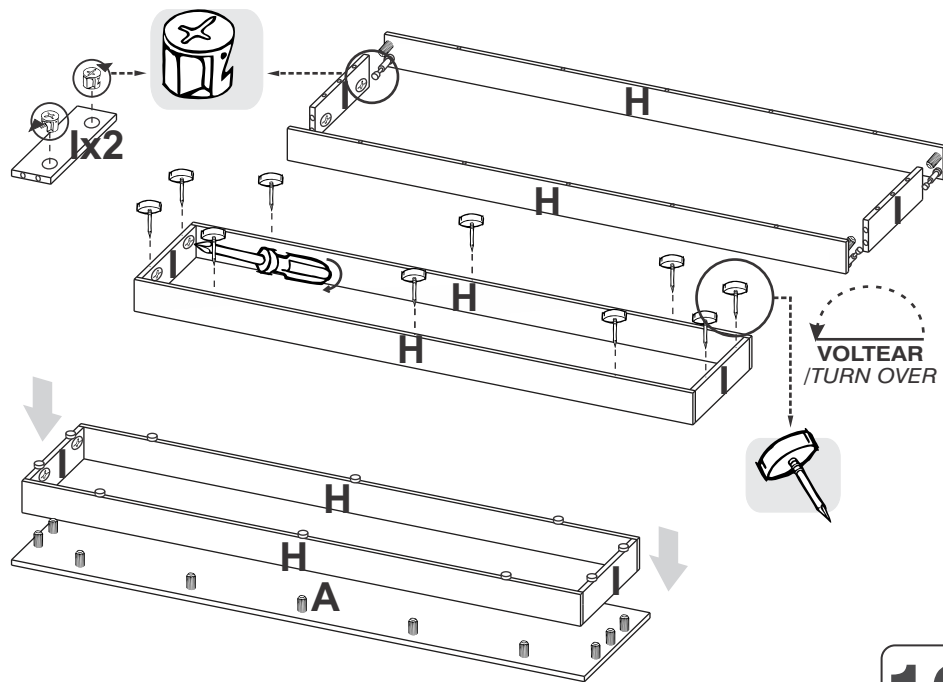
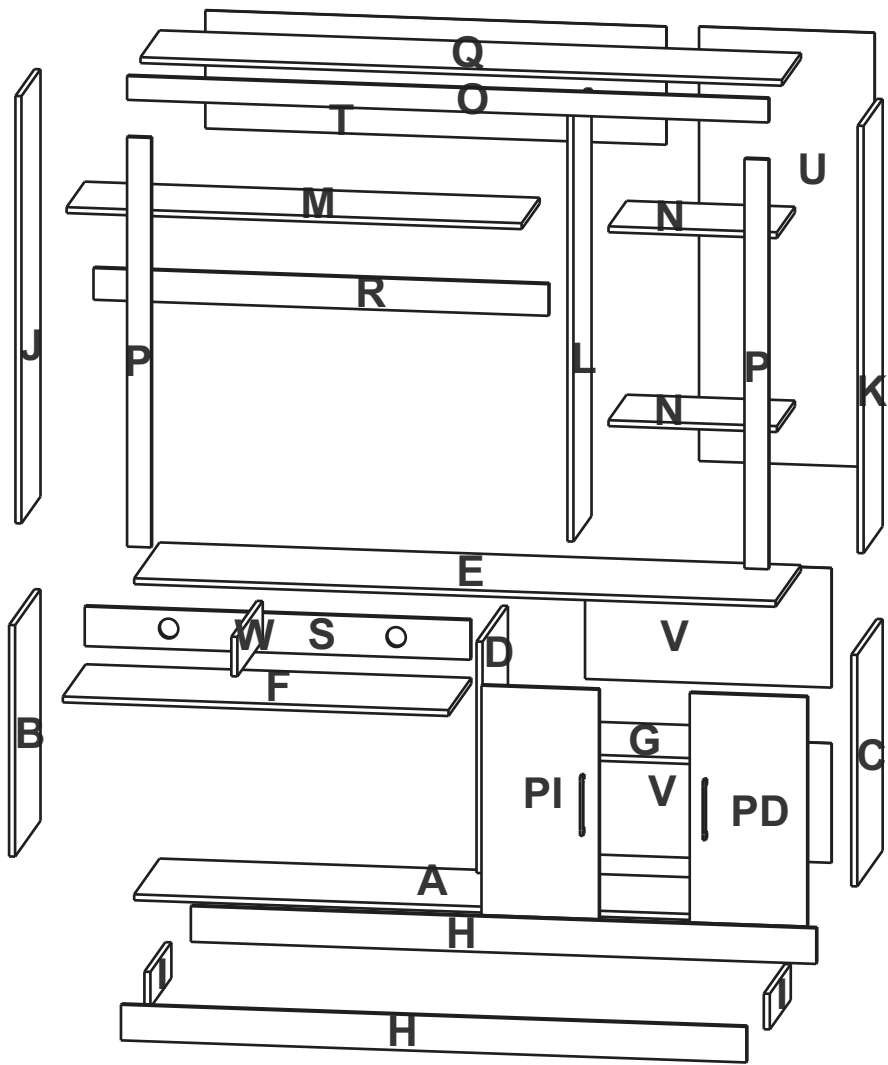

10

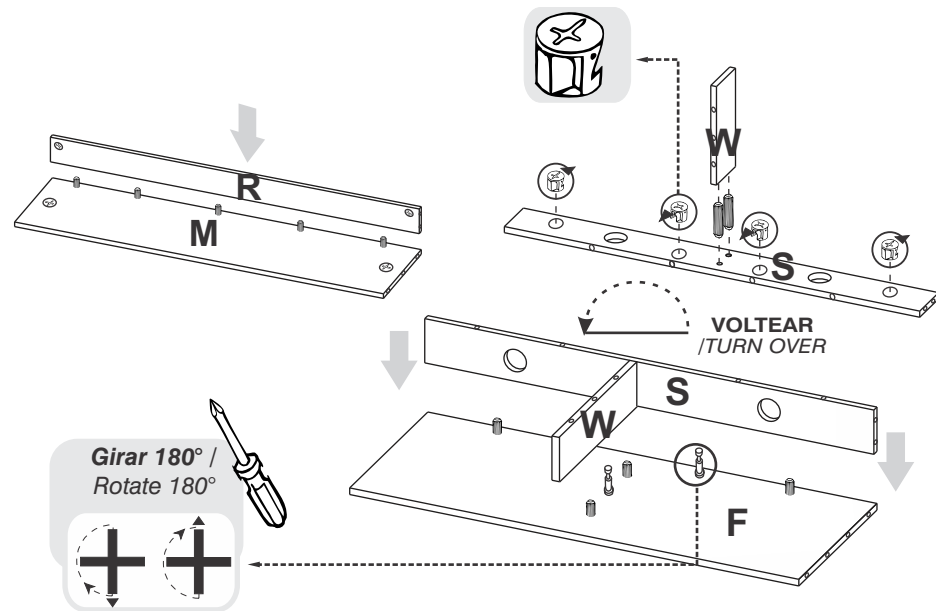

7

SE RECOMIENDA ARMAR EL MUEBLE SOBRE LA CAJA O SOBRE UNA SUPERFICIE LISA, PARA NO RAYARLO / IT IS RECOMMENDED TO ASSEMBLE THE PRODUCT ON THE BOX OR ON A PLANE SURFACE FOR NOT SCRATCH IT.

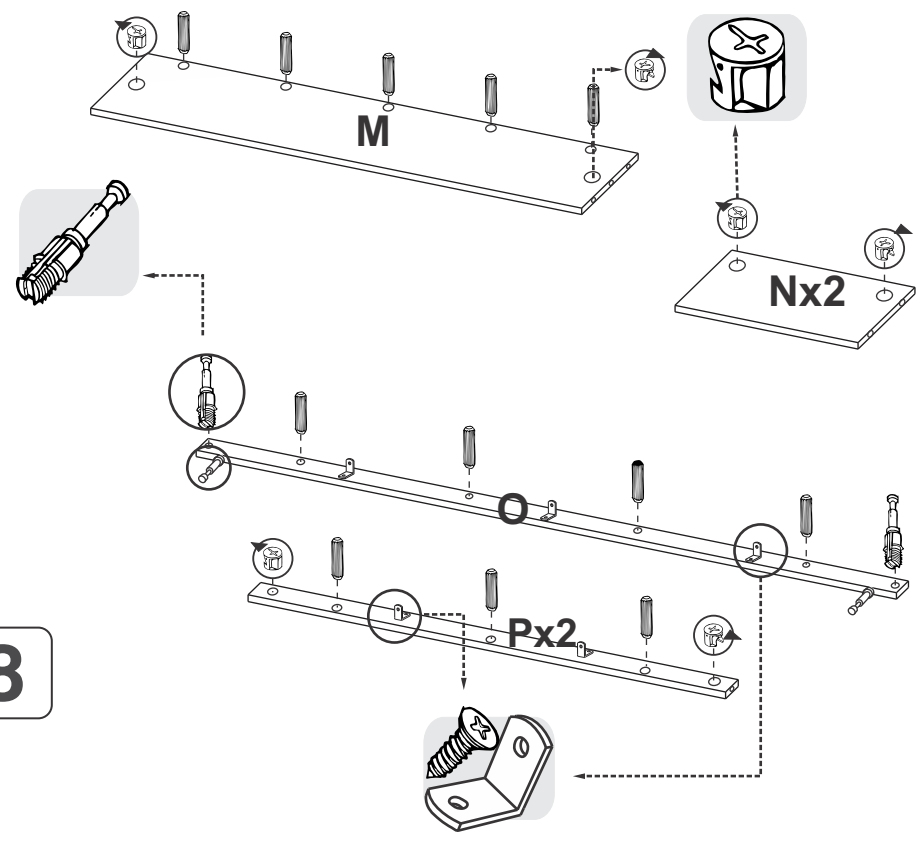

8

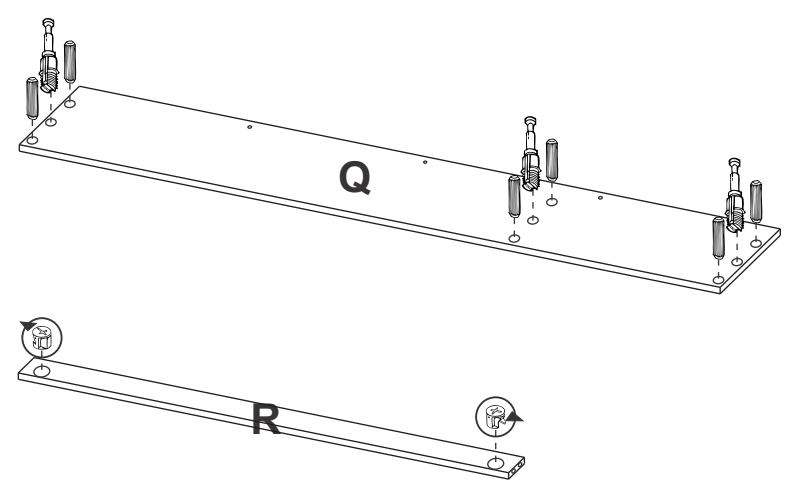

1



SE RECOMIENDA ARMAR EL MUEBLE ENTRE DOS PERSONAS / IT IS RECOMMENDED TO ASSEMBLE THE PRODUCT BETWEEN TWO PEOPLE

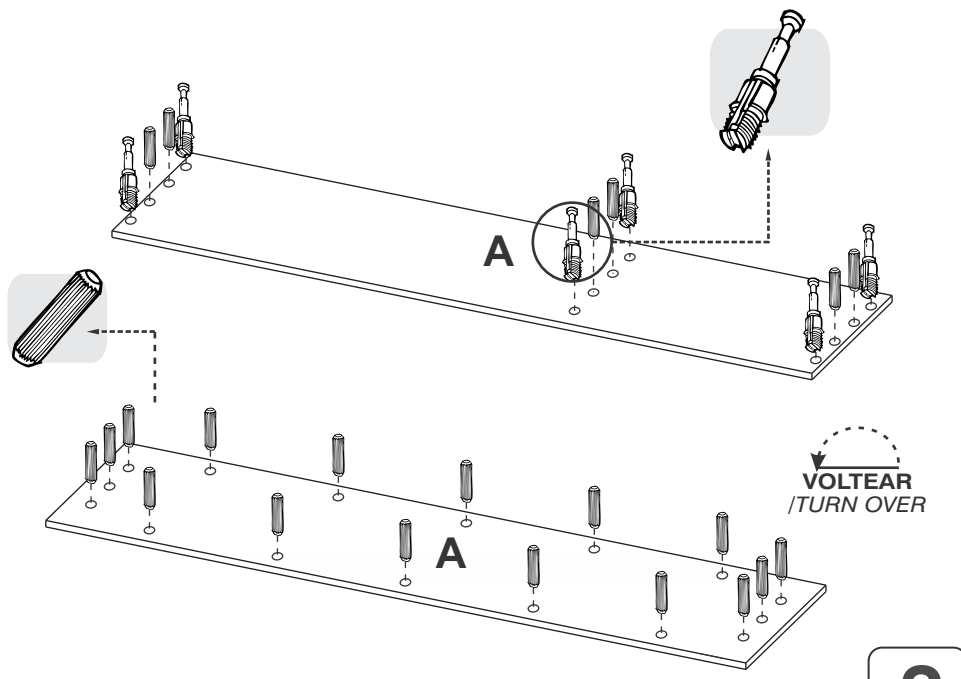

VOLTEAR / TURN OVER

2

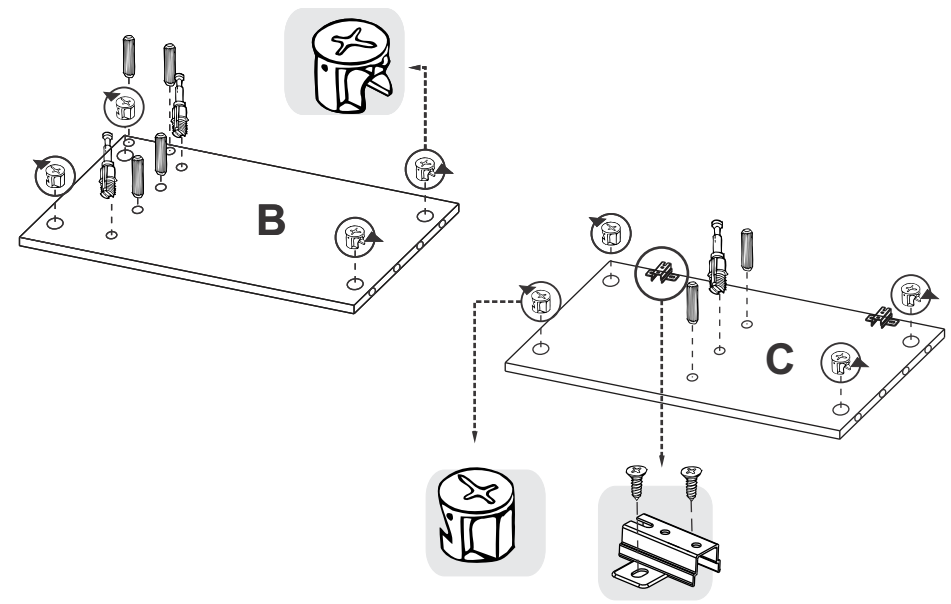

3

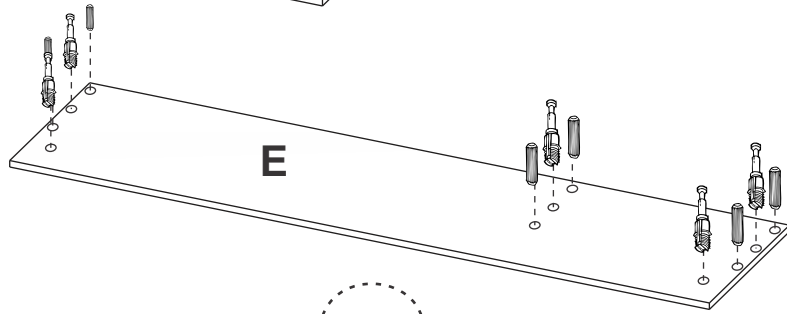
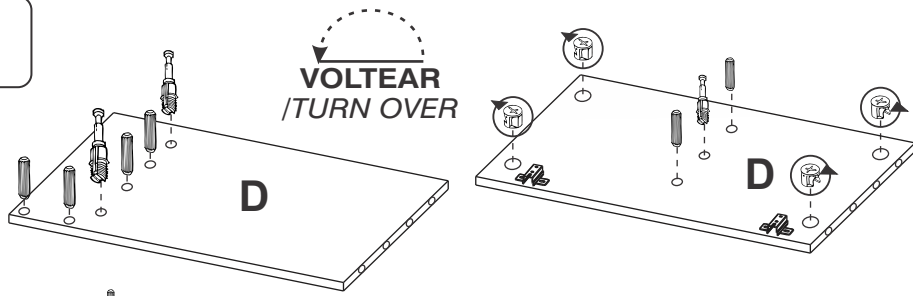

VOLTEAR / TURN OVER

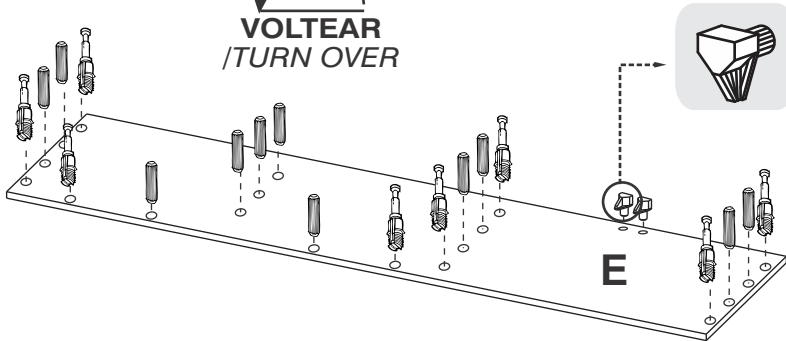

4

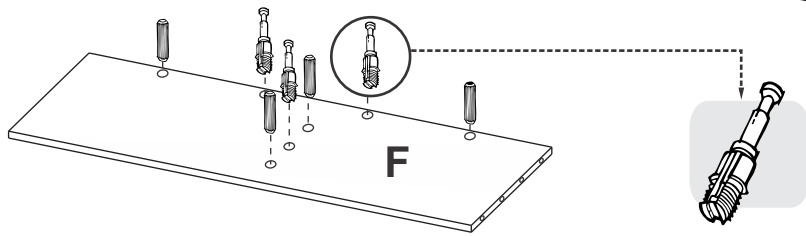

VOLTEAR / TURN OVER

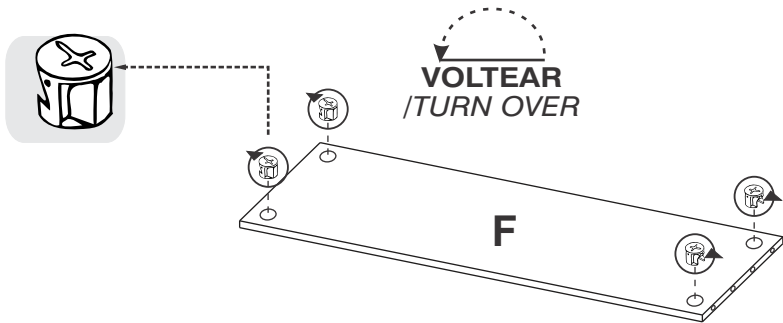

5

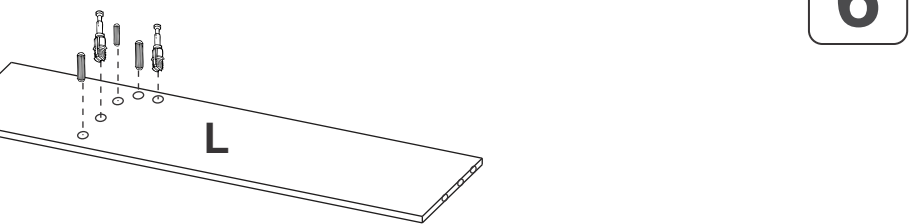
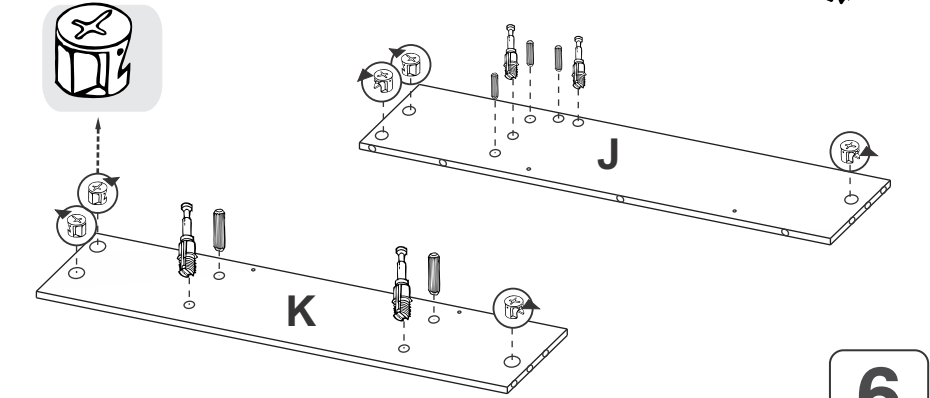
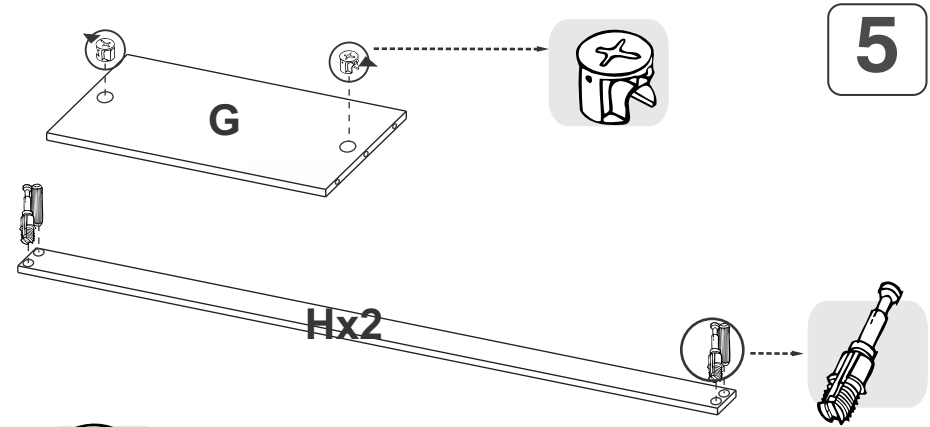

6

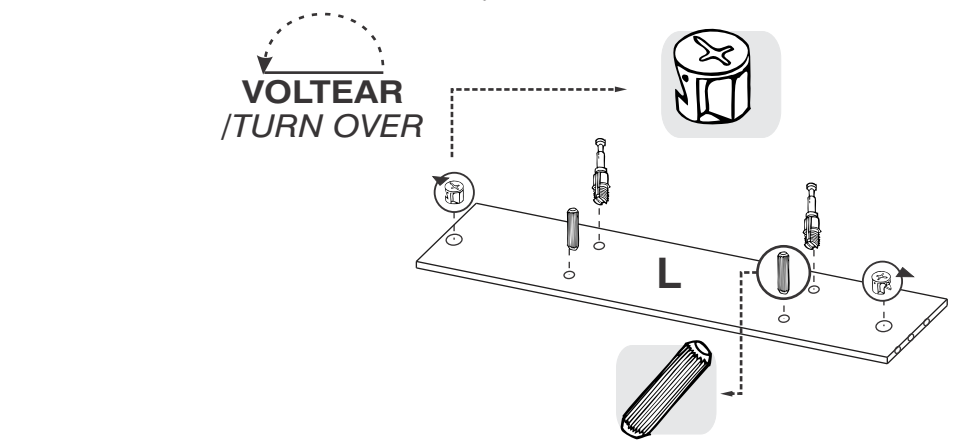

VOLTEAR / TURN OVER